

# OBI

INGLESE  
COD 22071 01/09

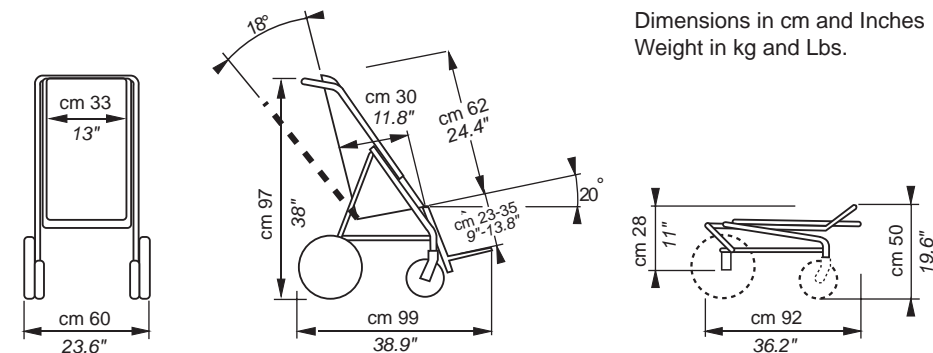

Dimensions in cm and Inches  
Weight in kg and Lbs.

**OBI 2** Weight with wheels kg 17,4 (Lbs. 38.3) - Weight without wheels kg 13,8 (Lbs. 30.4) - Max load kg 50 (Lbs. 110)

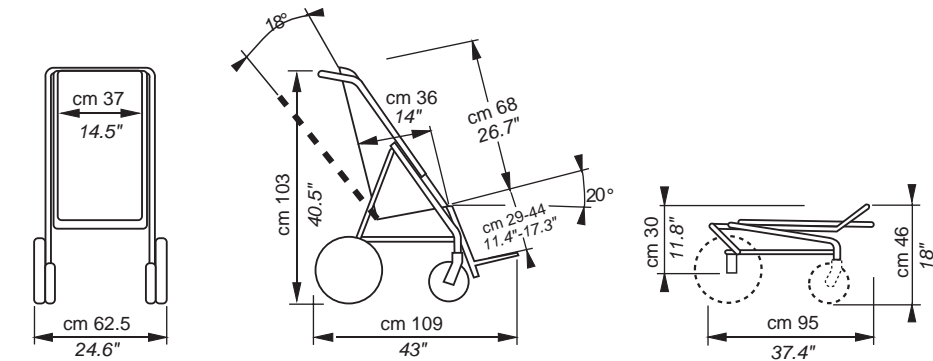

**OBI 3** Weight with wheels kg 18,5 (Lbs. 40.7) - Weight without wheels kg 14,8 (Lbs. 32.6) - Max load kg 60 (Lbs. 132)

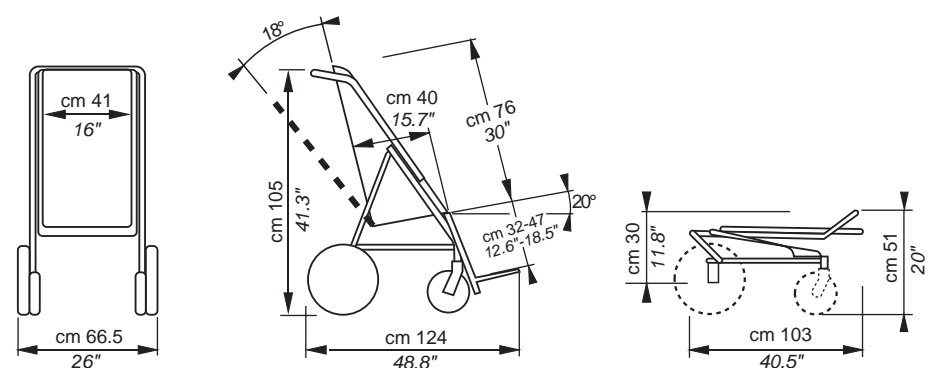

**OBI 4** Weight with wheels kg 20,1 (Lbs. 44.2) - Weight without wheels kg 16,4 (Lbs. 36.1) - Max load kg 70 (Lbs. 154)

THE NUMBERS DIVIDED BY THE DASH SPECIFY A MINIMUM AND A MAXIMUM ADJUSTMENT



Authorized Dealer

OBI is the result of our consolidated experience, our constant research on materials and our attempt to optimize postures. Particular attention has been paid form and colour as an integral part of the project.



OBI passed **CRASH TEST**  
according to the ISO 7176/19

Certified **CERAH** France



**ORMESA** S.r.l.

Via A. Da Sangallo, 1 - Loc. PACIANA  
06034 FOLIGNO (Pg) ITALY  
Tel.: +39 0742 22927 (r.a.)  
Fax: +39 0742 22637  
E-mail: info@ormesa.com  
http://www.ormesa.com

**ORMESA**

design and quality made in Italy



COMPANY  
WITH QUALITY MANAGEMENT  
SYSTEM CERTIFIED BY DNV  
= ISO 9001:2000 =



# ACCESSORIES

- Steel and aluminium **folding frame**, painted with non-toxic epoxy varnish
- **Trevira, padded, fire-retardant and removable upholstery**, machine washable at 30°
- **Chassis** made of natural-looking "cordura du pont" nylon, hard-wearing, washable



- 1 - slots for headrest
- 2 - slots for harness (853)
- 3 - side protections on the frame
- 4 - 828 chest belt (accessory)
- 5 - slots for abduction block
- 6 - quick release adjustment for the footrest
- 7 - adjustable tip-up footrest
- 8/9 - wheels sliding on ball bearings:  
front 17,5-cm. (7") swivel, unpierceable  
rear pneumatic 30-cm. (12") unpierceable rubber on request
- 10 - independent brake, light to use but hard wearing. No dangerous protuberances
- 11 - fold lock



834 Abduction block



835 Headrest with two side elements, which can be used one at a time (either the left side or the right side)



853 Adjustable harness



812 Wheel direction locks



817 Inguinal straps



816 Side supports

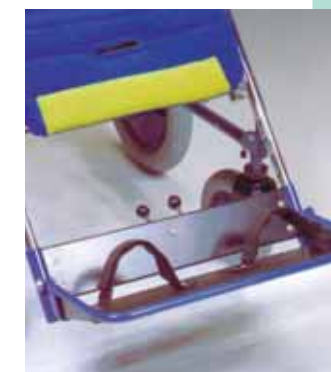

827 Foot straps



839 Front handle



894 45° Belt for the pelvis



858 Basket



824 Table with edge and hollow



837 Tray



891 Set of 4 tie down hooks for the forward-facing transport of the pushchair in a motor vehicle (private vans/cars, buses..)

#### WARNINGS:

- fits the ISO 10542 compliant 4-POINT STRAP-TYPE TIEDOWN, provided by the vehicle
- it is required for the child to wear both pelvic- and shoulder-belt-type restraints, to be compliant either with ISO 7176-19 or ISO 10542. Postural belts and harnesses such as our 828, 853 and 894 are not approved for the use as an occupant restraint system, but they can be used in addition
- the vehicle must be suitable for transporting orthopedic pushchairs in compliance with current law
- read the warnings and instructions given in the user's & maintenance book



- Rigid backrest with four quick release recline positions
- Rigid fixed seat
- Quick release reclinable legrest



819 Canopy



825 Rain cover



818 Thermic cover



832 Optional frame for narrow passages and lifts (the external width is reduced by 7 cm (3"). Light undetachable wheels with solid tyres; 20 cm (8") rear wheels, 17 cm (7") front wheels, on all bearings.



833 Base with 12" wheels